

REVISIONS				
ECN	REV	DESCRIPTION	DATE	BY/APPVL
10207	00	NEW	09-07-10	DJB/JDN
11840	A	DISCONNECT SHIELDS FROM CHASSIS GROUND, CONNECT TO ELECTRONICS COMMON	10-25-13	DJB/MC

NFPA J-BOX

KIT 4053501

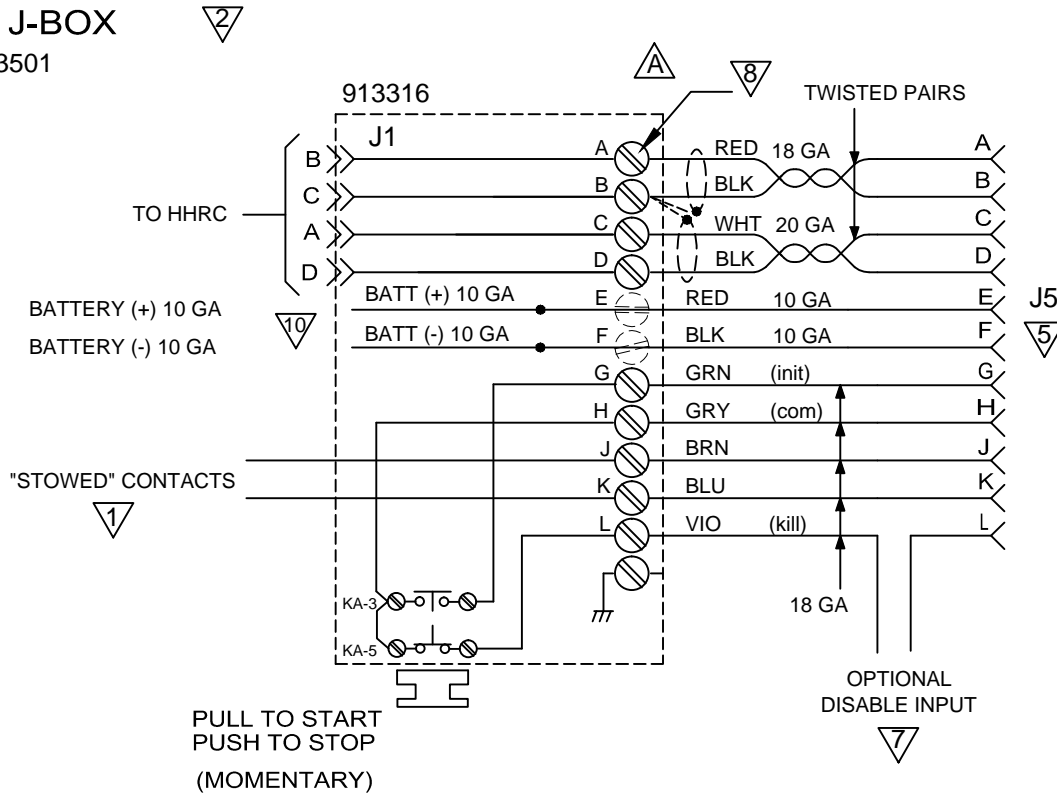

NOTES

- USE SW1 POSITION 6 ON BASE BOARD TO SELECT OPEN OR CLOSED WHEN NESTED.
SW1-6 OPEN = CONTACTS CLOSED WHEN NESTED
SW1-6 CLOSED = CONTACTS OPEN WHEN NESTED.
2 AMPS MAX CURRENT, 20 GA. MINIMUM CONDUCTOR.
- SW1 POSITION 5 ON BASE BOARD MUST BE OPEN (NFPA MODE)
- SW1 POSITION 5 ON BASE BOARD MUST BE CLOSED (STANDARD MODE)
- REMOVE JUMPER(S) IF REPLACED BY PARKING BRAKE INTERLOCK. G-L CLOSED WHEN BRAKE "ON".
- 4032502 (30 FT. CABLE), 4032503 (50 FT. CABLE). TO J5 ON POWERLITE BASE BOARD.
- 4032101 (20 FT. CABLE), 4032102 (50 FT. CABLE)
- OPTIONAL DISABLE INPUT, CUSTOMER SUPPLIED CONTACTS. MUST HAVE CONTINUITY TO FUNCTION. WILL NOT ALLOW OPERATION IF OPEN, ACTS AS EMERGENCY STOP.
- 4.4in-lbs, 0.5Nm
- 20 in-lbs, 2.3Nm
- BATTERY CONNECTION TO SYSTEM: IN-LINE SPLICE RECOMMENDED. DO NO USE E AND F.

AutoCAD Drawing: NS J-Box Wiring DWG	UNLESS OTHERWISE SPECIFIED DIMENSIONS ARE IN INCHES TOLERANCES ON: DECIMALS ANGLES 0 = ± 1/2" 00 = ± .010" 000 = ± .005" FRACTIONS ± BREAK ALL SHARP CORNERS ON ALL MACHINED SURFACES	THIS DOCUMENT CONTAINS PROPRIETARY INFORMATION AND SHALL NOT BE USED OR REPRODUCED OR ITS CONTENTS DISCLOSED IN WHOLE OR IN PART WITHOUT THE PRIOR WRITTEN CONSENT OF THE WILL-BURT COMPANY. FOR LOGISTICAL SUPPORT ONLY	AN EMPLOYEE OWNED COMPANY ORRVILLE, OHIO
FINISH		SIGNATURE DR. BY DJB CK. BY JDN APP. BY	DATE -
		SIZE B	DWG. No. WD-72102
		SCALE NTS	SHEET 1 OF 1